

# Throttle Body

P/N 30.41.100-D-HT, P/N 30.41.105-D-HT

## Variations

- Standard diameters D of the throttle (*see drawing*) 60 mm (2.36"), 68 mm (2.68")
- Possible diameters of the throttle 48 mm (1.89") to 68 mm (2.68")

## Dimensions

- Length/width of mounting flange 111.7 mm (4.40")
- Hole spacing on the mounting flange 75 mm (2.95")
- Height of mounting flange 61 mm (2.40")

## Gasket (P/N 30.41.100-D-HT only)

- Type O-ring
- Inside diameter 82.14 mm (3.23")
- Cross section 3.53 mm (0.14")

## Weight

- P/N 30.41.105-55-HT 1.1 kg (2.43 lbs)
- P/N 30.41.100-60-HT, P/N 30.41.105-60-HT 1.0 kg (2.20 lbs)
- P/N 30.41.100-68-HT, P/N 30.41.105-68-HT 0.9 kg (1.98 lbs)

## Mechanical Data

- Maximum rotation angle of the throttle 80°
- Chemical resistance Water, oil, gaseous fuels
- Absolute pressure 4.5 bar (65 psi)
- Maximum temperature of media flowing through +200 °C (+392 °F)

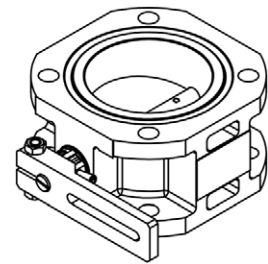

## Overview Drawings

### P/N 30.41.100-D-HT

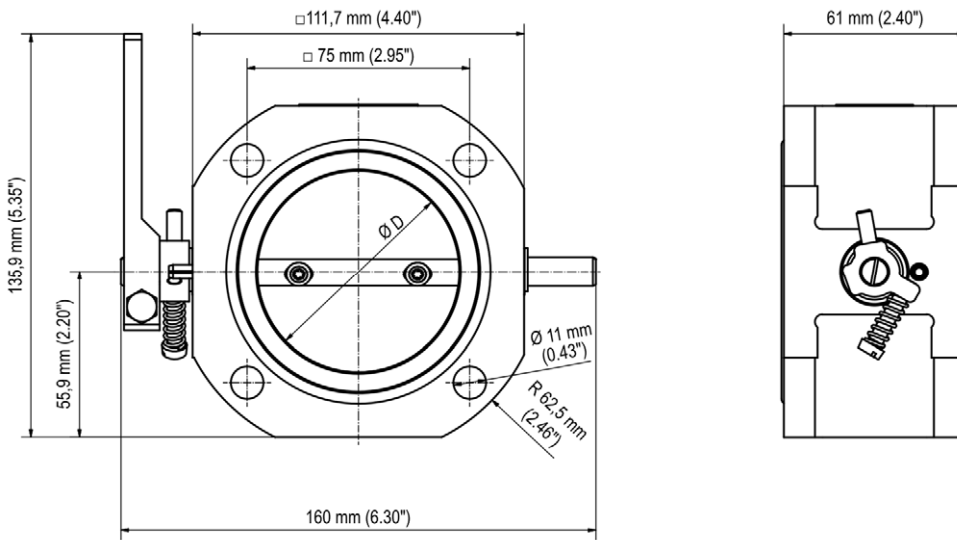

### P/N 30.41.105-D-HT

